



*Working for a cleaner, safer world™*

# 6100 Power Sweeper



# The Compact Advantage

The compact size and maneuverability of the Model 6100 means it goes almost anywhere.

This new rider sweeper easily handles congested industrial facilities, narrow-aisled warehouses, and many other applications. Designed to clean various surfaces from smooth concrete to finished floors, the 6100 can also be used on carpets. It's ideal for picking up small debris and light litter. And as one of the smallest rider sweepers in the world, the 6100 is an excellent value.

## VCS™ System: Breakthrough Filtration Technology

The patented VCS™ system filter-shaker saves you time and labor. It cleans the filter panel pleat by pleat for the most effective clean-back in the industry. The VCS™ system improves overall performance by enabling the 6100 to run longer between filter cleanings. Manual filter-cleaning time is reduced or eliminated altogether.

## Productivity-Enhancing Options

The 6100's cleaning capacity can be tailored to fit the application. Adding a second side brush extends the cleaning path and gives you an edge-cleaning tool on both sides of the unit. Plus, a QuickMop™ feature provides light cleaning and widens the cleaning path to 5-1/2 feet (1.67 m), making the small 6100 the largest-capacity unit in its class.

Both side brushes and the QuickMop™ feature retract, enabling the unit to fit through a space as narrow as 32 inches (820.5 mm). The vacuum wand picks up stray litter, with vacuum suction starting instantly when the wand is pulled from its holster.



The 6100 is so compact it can move between floors using a standard passenger elevator.



The patented new VCS™ filter-shaking system incorporates breakthrough technology that makes all manual filter-shaking systems obsolete. Includes a clogged-filter indicator as well as a timed 10-second shakedown.

# 61



The Model 6100 offers the compact advantage when it comes to warehouse sweeping. It can maneuver down the most congested aisles and turn in the tightest spaces.



The QuickMop™ feature attaches to the front and widens the cleaning path to 5-1/2 feet (1.67m). Perfect for smooth concrete and finished surfaces.



Light enough to go over carpets for gentle yet thorough sweeping through carpeted environments.

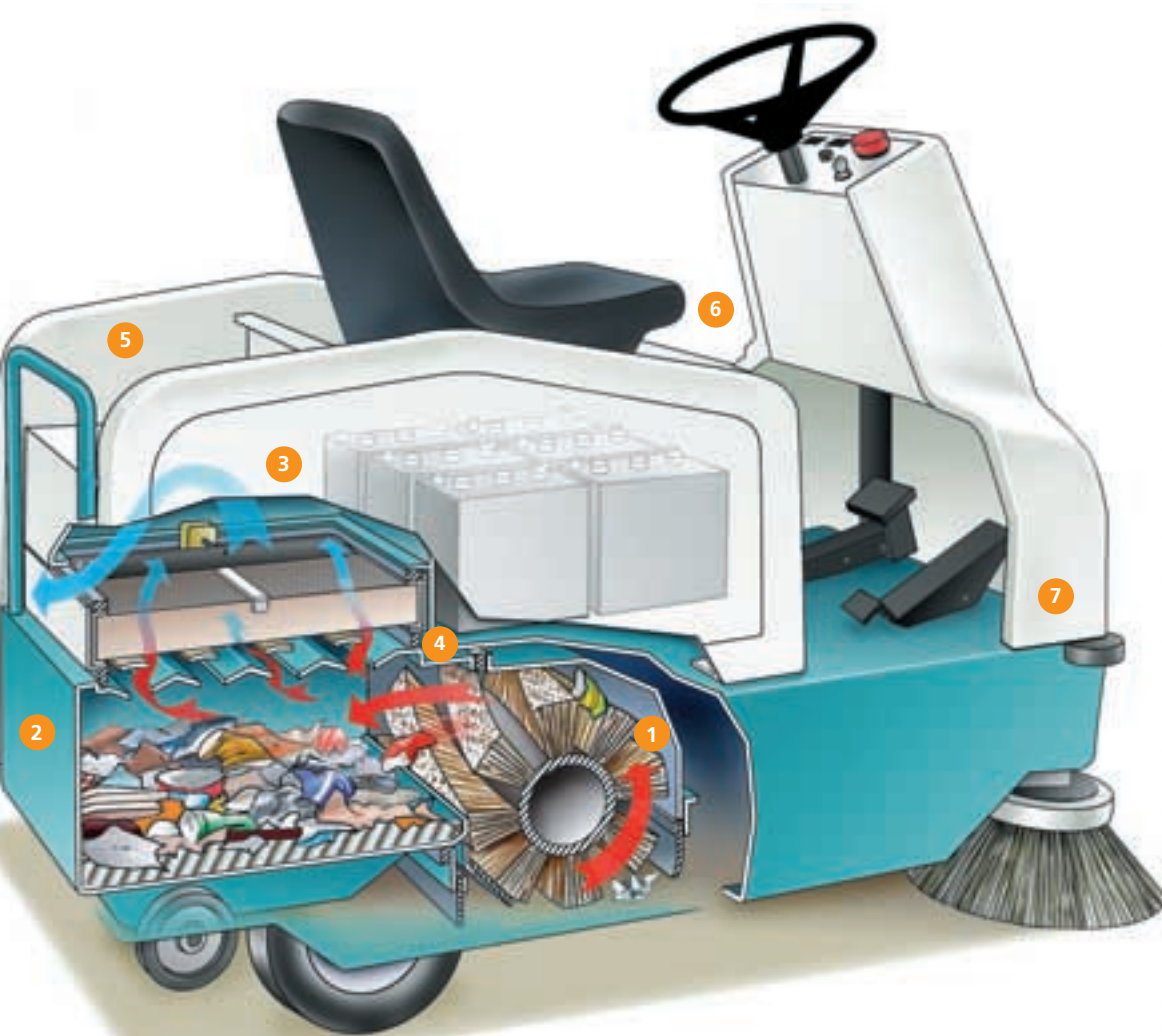

### The Model 6100

- 1 Patent-pending sweeping technology ensures good performance even with worn brushes.
- 2 Glide-out hopper with large built-in wheels easily transports debris.
- 3 VCST™ filter-shaking system effectively cleans filter; dual fail-safe filter seal ensures dust control.
- 4 No-tool brush and filter change minimize downtime.
- 5 Utility tray behind operator carries cleaning supplies to enhance productivity.
- 6 Access from both sides of the unit offers 360° visibility and allows operator to move easily into and out of seat in congested spaces.
- 7 In tight spots, corner rollers help protect property and machine.

# 6100 Power Sweeper

## Specifications\*

### Propelling System

Battery package	36 volt	220 AH
Propelling motor	.75 hp	.56 kW
Gradeability		
Full hopper	8° / 14.1%	
Empty hopper	10° / 17.6%	
Propel speed		
Forward (variable to)	5 mph	8 km/h
Reverse (variable to)	3 mph	4.8 km/h
Minimum aisle turn	72 in	1830 mm

### Sweeping System

Cleaning path (one sidebrush)	30 in	760 mm
Cleaning path (two sidebrushes)	38 in	960 mm
Main brush length (tubular)	22 in	560 mm
Main brush drive		Belt
Hopper volume capacity	3 ft <sup>3</sup>	85 L
Hopper weight capacity	200 lb	90 kg

### Dust Control System

Filter area	33.7 ft <sup>2</sup>	3.13 m <sup>2</sup>
Vacuum fan speed		4375 rpm

### Tennant Value Added Features Include:

Glide-in/out poly-wheeled hopper	Corner rollers all-around
Large built-in utility tray	No tool brush change
32" doorway pass-through	Instant access™ panel filter w/ VCS™ system

### Optional Equipment

Audio backup alarm	GlideBy™ protective molding
QuickMop™ feature	Non-marking tires
Vac wand	Left-handed side brush
Roll-out battery package	

## Dimensions

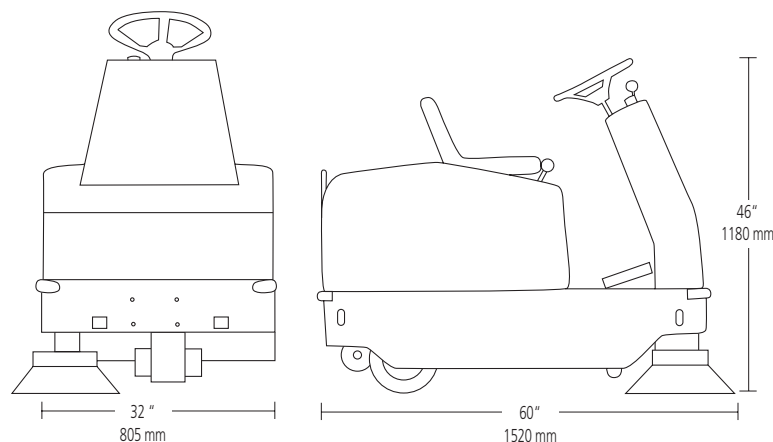

The handy optional vacuum wand cleans out-of-the-way spaces, with vacuum suction starting instantly when the wand is pulled from its holster.



A unique glide-out hopper with large, built-in wheels easily moves and empties debris.

\*Subject to change without notice. (Some options not available in all countries.)

*Working for a cleaner, safer world™*

Tennant Company offers the most complete line of floor and surface maintenance equipment, floor coatings, brushes, and cleaning detergents in the world. Our sales and service networks are able to provide you with integrated custom cleaning solutions to meet any floor care need.

ISO 9001 Certified

*Authorized Tennant Representative*

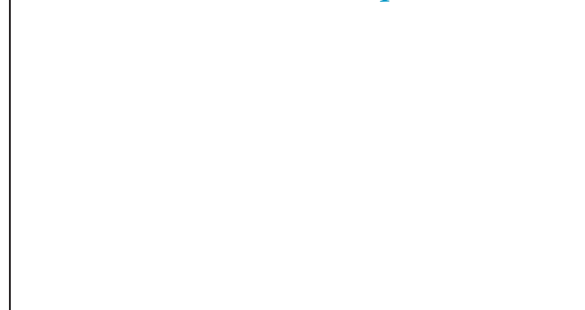

### Tennant Company

P.O. Box 1452  
Minneapolis, MN U.S.A. 55440  
Call toll-free: 1-800-553-8033  
In Quebec call: 514-335-6061  
Fax: 763-540-1437  
www.tennantco.com

### Tennant Company, Commercial Products

12875 Ransom Street  
Holland, MI 49424  
Call toll-free: 1-800-522-7839  
Ph: 616-786-2349  
Fax: 616-786-2345